

® Digital Sprint Press

MEGA PART NOS: **70-1001 (28 x 38cm)**
 70-1009 (40 x 50cm)



MEGA ELECTRONICS LIMITED

Mega House, Grip Industrial Estate,
Linton, Cambridge, England. CB21 4XN

Tel: +44 (0) 1223 893900 Fax No: +44 (0) 1223 893894
email: sales@megauk.com web: www.megauk.com

Operators Manual

www.megauk.com

TABLE OF CONTENTS

IMPORTANT SAFETY INSTRUCTIONS	3
DIGITAL SPRINT PARTS LOCATION GUIDE	4
DIGITAL SPRINT CONTROL PANEL	5
OPERATING INSTRUCTIONS	6-11
DIGITAL SPRINT ELECTRIC SCHEMATIC	12

Important Safety Instructions

WHEN USING YOUR APPLIANCE, BASIC PRE-CAUTIONS SHOULD ALWAYS BE FOLLOWED, INCLUDING THE FOLLOWING:

- 1 Read all instructions.
- 2 Use appliance only for its intended use.
- 3 To reduce the risk of electric shock, do not immerse the appliance in water or other liquids.
- 4 Never pull cord to disconnect from outlet, instead grasp plug and pull to disconnect.
- 5 Do not allow cord to touch hot surfaces, let appliance cool completely before putting away.
- 6 Do not operate appliance with a damaged cord, or if the appliance has been dropped or damaged. To reduce the risk of electric shock, do not disassemble or attempt to repair the appliance, take it to a qualified service person for examination and repair. Incorrect reassembly or repair could cause a risk of fire, electric shock, or injury to persons when the appliance is used.
- 7 Close supervision is necessary for any appliance being used by or near children. Do not leave appliance unattended while connected.
- 8 Burns could occur from touching hot metal parts.
- 9 To reduce the likelihood of circuit overload, do not operate another high voltage appliance on the same circuit.
- 10 If an extension cord is absolutely necessary, a 20 ampere rated cord should be used. Cords rated for less amperage may overheat, care should be taken to arrange the cord so that the cord cannot be pulled or tripped over.

SAVE THESE INSTRUCTIONS

Digital™ Sprint® Press

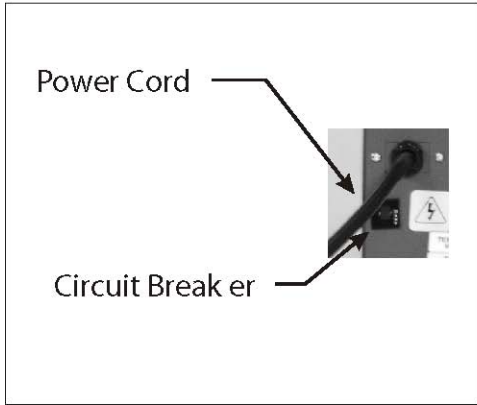

* Featured on the opposite side of the press

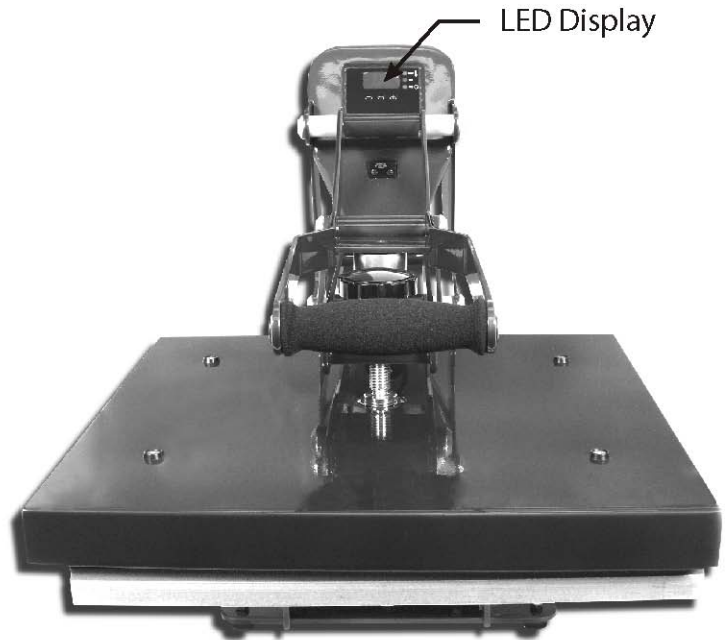

FRONT VIEW

12 V Magnet (on optional auto release only)

Power On/Off Switch

Pressure Adjustment Knob

Lift Handle

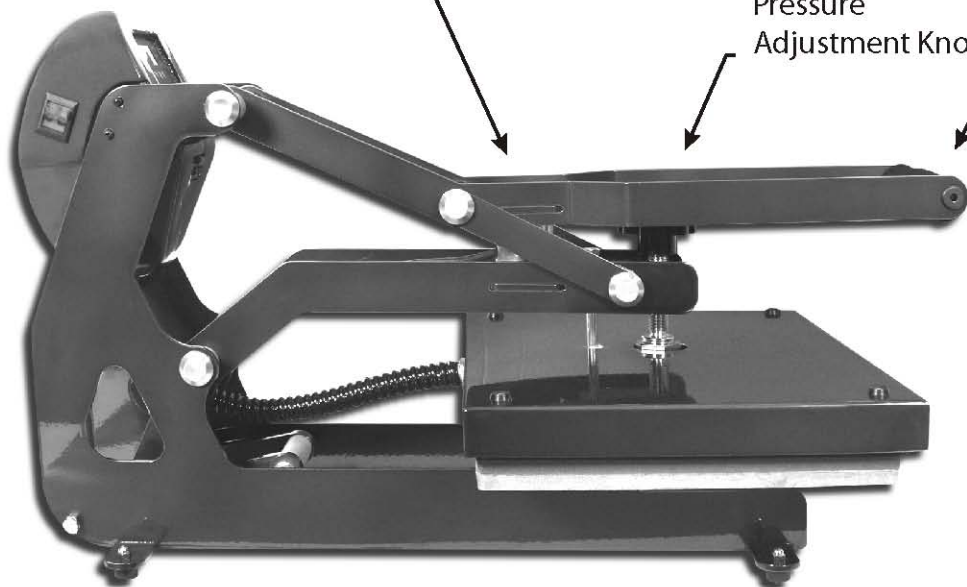

SIDE VIEW

CONTROL PANEL

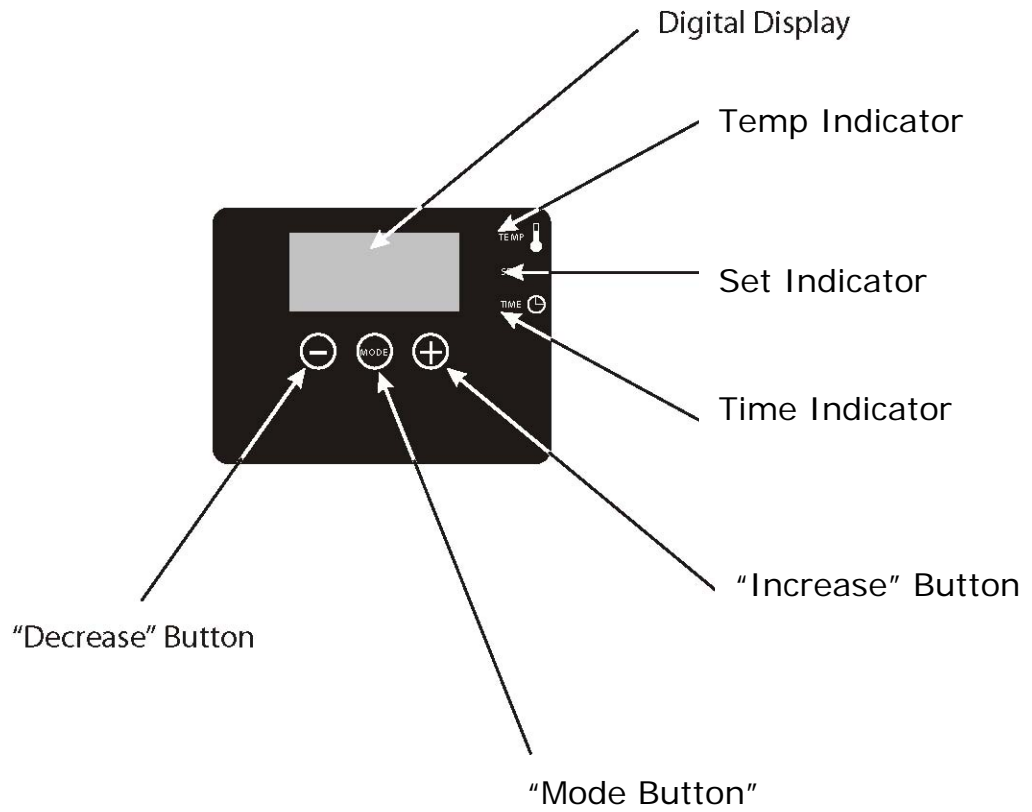

OPERATING INSTRUCTIONS

Carefully read and follow the step-by-step instructions for best results.

If you experience any difficulty, carefully re-read the instructions and try again.

Pay particular attention to the risk of burns which can be sustained by touching the heated platen during use.

Keep hands clear from the platens of the press during platen lock down as the pressure can cause injury .

Press should be placed on a sturdy suitable stand at least 36"L x 24"W x 29"H.

Work area must be kept clean, tidy and free of obstructions to the movements of the heat press.

Power supply cord must be disconnected before cleaning or servicing press.

Step 1

CONNECT THE POWER CORD:

Connect the power cord into a properly grounded electrical outlet with a sufficient amperage rating.

120 Volt

Your DIGITAL SPRINT requires a full 15 amp grounded circuit for 120 volt operation.

240 Volt

Your DIGITAL SPRINT requires a full 7.5 amp grounded circuit for 240 volt operation.

Extension Cords, if used, should be as short as possible and not less than 12 gauge. Heavy duty cords are recommended. Circuits that have under 15 amps or other high demand equipment or appliances (especially more than one heat seal machine) should not be used.

NOTE: If the supply cord is damaged, it must be replaced by the manufacturer its service agent or a similarly qualified person in order to avoid hazard.

Use HSJ type, rated 250 V - 10 AMP for replacement.

CAUTION

FAILURE TO FOLLOW THESE INSTRUCTIONS WILL CAUSE:

- 1 Erratic controller functions.
- 2 Inaccurate displays and slow heat-up.
- 3 The circuit breaker to disengage.

Step 2

SWITCH THE SYSTEM ON

A. Auto Release Unit

Remove from carton Locate the packaging bolt positioned on top centre of press. Packaging bolt must be removed prior to turning press on or operating press. Locate the Power ON/OFF Switch on press. Turn the Power Switch on.

B. Manual Release Unit

Locate the lift handle and position the heat platen in the up (load) position. Locate the Power ON/OFF Switch on the press. Turn the Power Switch on.

POWER ON/POWER OFF SWITCH

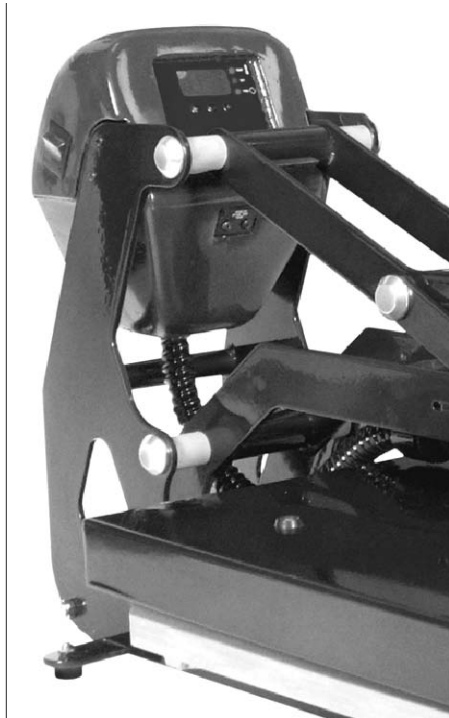
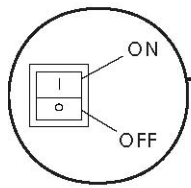

ADJUST THE TEMPERATURE

Locate the LED Display on the Press.

Press the Mode Select Button located in the centre of the Control Panel. The (SET) and (TEMP) Lights located next to the display will illuminate indicating you are in the Adjust Temperature Mode.

Next, press the (-) Button located to the left of the Mode Select Button to lower the temperature setting, or press the (+) Button located to the right of the Mode Select Button to raise the temperature setting. The temperature can be set from 96°C (205°F) to 221°C (430°C).

The LED will display your changes as you make them.

NOTE: The temperature indicator will only display temperatures 96°C (205°F) and up.

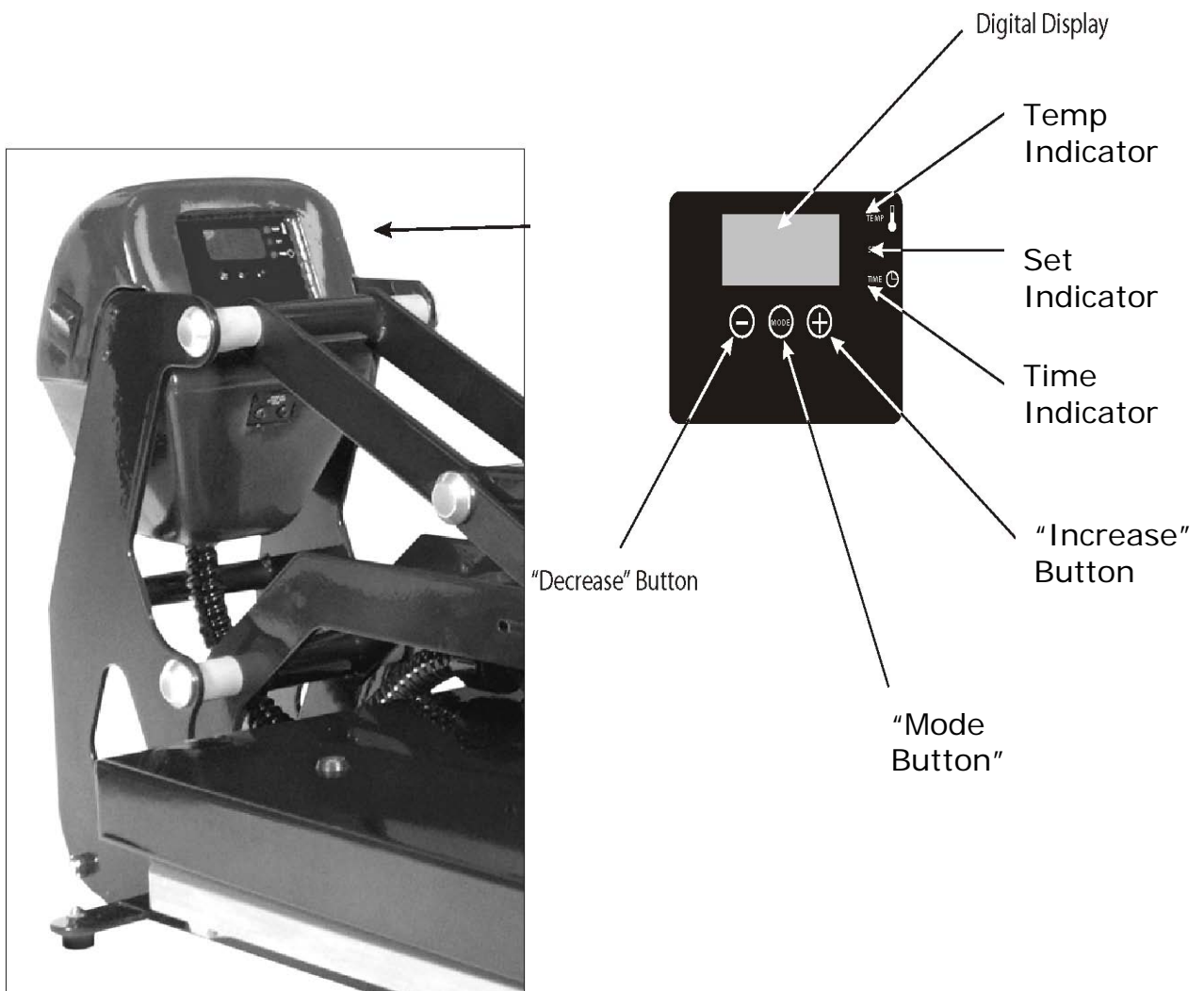

Step 4

ADJUST THE TIME

Once you have completed adjusting the temperature press the Mode Select Button again. This will advance you to the Adjust Time Mode. The (SET) and (TIME) Lights will illuminate, indicating you are in the Adjust Time Mode. Adjust the time in the same manner that you adjusted temperature. The time can be set from 001 to 999 seconds.

To exit the Adjust Temperature and Time Modes press the Mode Select Button a third time. All lights will be off and the press will return to the Print Mode.

IMPORTANT :

The press will not function when the (SET) Light is illuminated. This light indicates that you are in the Adjust Temperature or Time Mode not the Print Mode.

REMEMBER :

PRESS the MODE SELECT button ONCE to advance to the ADJUST TEMPERATURE MODE.

PRESS the MODE SELECT button AGAIN (Second Time) to advance to the ADJUST TIME MODE.

PRESS the DECREASE and INCREASE buttons to make the changes desired.

Step 5

ADJUST THE PRESSURE

The Pressure Adjustment Knob is located in the centre of the heat platen. Adjust the pressure by turning the knob clockwise to increase pressure and counter clockwise to decrease pressure.

REMEMBER:

To allow for the thickness of your garment when adjusting the pressure.

WARNING:

STRUCTURAL DAMAGE CAUSED BY EXCESSIVE PRESSURE IS NOT COVERED UNDER THE LIMITED WARRANTY!

Pressure Adjustment Knob

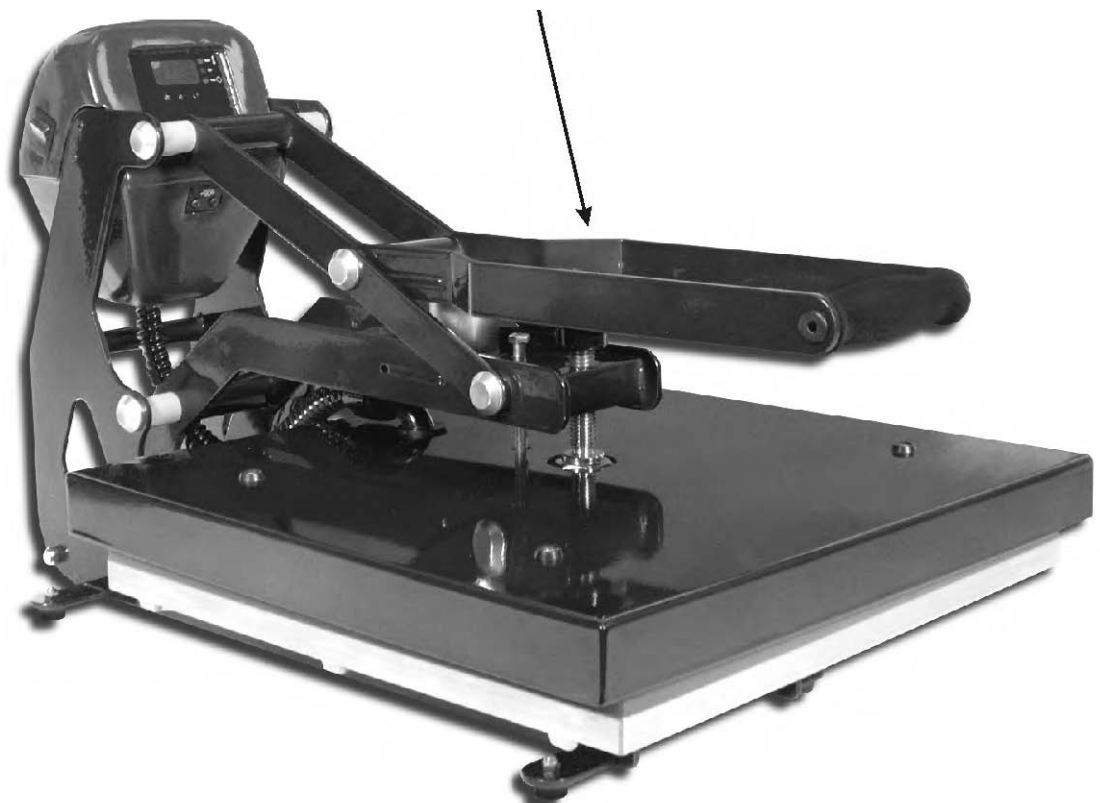

Step 6

PRINT

Once your equipment has reached the designated temperature, position the garment and application and proceed to press.

Lower and lock the heat platen into the press position. This procedure will start the automatic timing process.

A. Auto Release Unit

The timer will automatically count down and audibly signal you to lift the heat platen into the "UP" position when the press cycle is complete. Please be aware after time is complete gas shocks will automatically release the platen into the "up" position.

B. Manual Release Unit

The timer will automatically count down and audibly signal you to lift the heat platen into the "UP" position when the press cycle is complete.

The time will automatically re-set and you are ready to continue with the next application.

93°C (200°F)

= The lowest temperature the unit will display

96°C (205°F)

= The lowest set temperature possible

221°C (430°F)

= The highest set temperature possible and the highest temperature the unit will display



ELECTRICAL SCHEMATIC

